 **Batteries included**

Description

MClimate PIR mini LoRaWAN is a compact stand-alone sensor powered by 2xAA batteries lasting for up to 15 years with the default configuration. The device features PIR (occupancy) sensor, as well as temperature, humidity and lux sensors.

The data from the PIR mini can be used in any LoRaWAN compatible system, incl. Building Management Systems to control demand-based ventilation. Sensor information can be exposed as datapoints in Modbus, BACnet and KNX systems through the use of a special gateway.

SKU: MC-LW-PIR-MINI-01-BI

Product features

- PIR (occupancy) sensor
- LUX sensor
- Temperature and Humidity sensor
- Firmware Update Over The Air (FUOTA)
- Ultra low power consumption
- Sends message on occupancy
- Counts total number of movements
- Double-sided tape on the back

Applications

- Smart Buildings
- Residential buildings
- Commercial buildings
- Hotels

Device specifications

Mechanical specifications

WEIGHT EXCL. BATTERIES	34gr
DIMENSIONS	57.5mm x 57.5mm x 21.7mm
ENCLOSURE	PC/ABS
MOUNTING OPTIONS	Screws and dowels or double-sided tape (included); Anti-theft bracket with secure screw

Operating conditions

TEMPERATURE	0° - +60°C
HUMIDITY	0-95% RH (non-condensing)

Power supply

POWER SUPPLY	2xAA batteries (each 1.5VDC)
OPERATING VOLTAGE	3.0VDC
EXPECTED BATTERY LIFE	Up to 15 years with default configuration (depending on radio environment)

Radio/Wireless

WIRELESS TECHNOLOGY	LoRaWAN® 1.0.3
WIRELESS SECURITY	LoRaWAN® End-to-End encryption (AES-CTR)
LORAWAN DEVICE TYPE	Class A End-device
SUPPORTED LORAWAN FEATURES	OTAA, ADR, Adaptive Channels setup
SUPPORTED LORAWAN REGIONS	EU863 – 870; Other LoRaWAN regional settings available upon request
LINK BUDGET	130dB
RF TRANSMIT POWER	14dB

Sensors

Temperature

RESOLUTION	0,1°C
ACCURACY	±0,2 - ±0,3°C

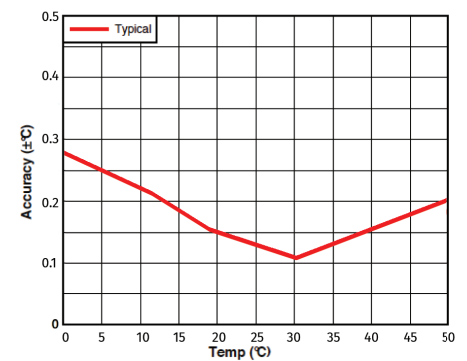

Humidity

RESOLUTION	±2
ACCURACY	±3% r.H.

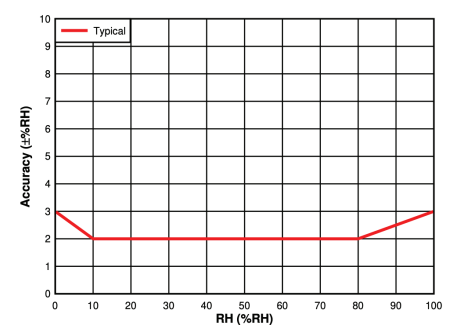
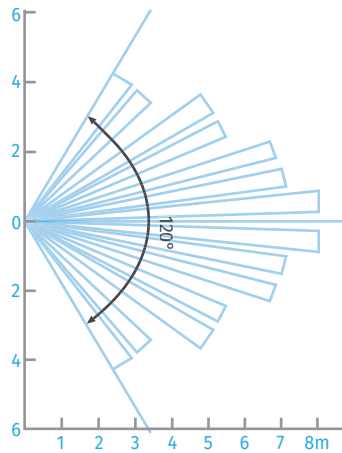

Figure 6-1. RH Accuracy vs. RH

PIR

VIEW OF ANGLE

X=120° ; Y = 120°



TOP VIEW

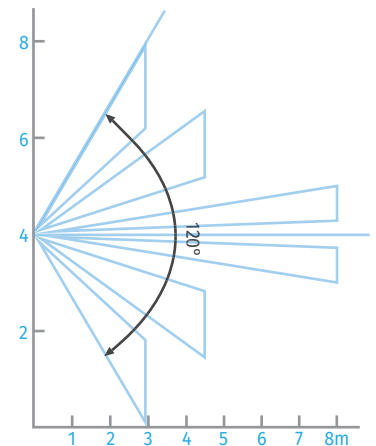

SIDE VIEW

LUX

RANGE

0 - 65530 lux

RESOLUTION

1 lux

ACCURACY

+/-10%

* Since the LUX sensor is positioned behind the lens, accuracy may vary depending on the angle of incidence of the incoming light.

Placement guidelines

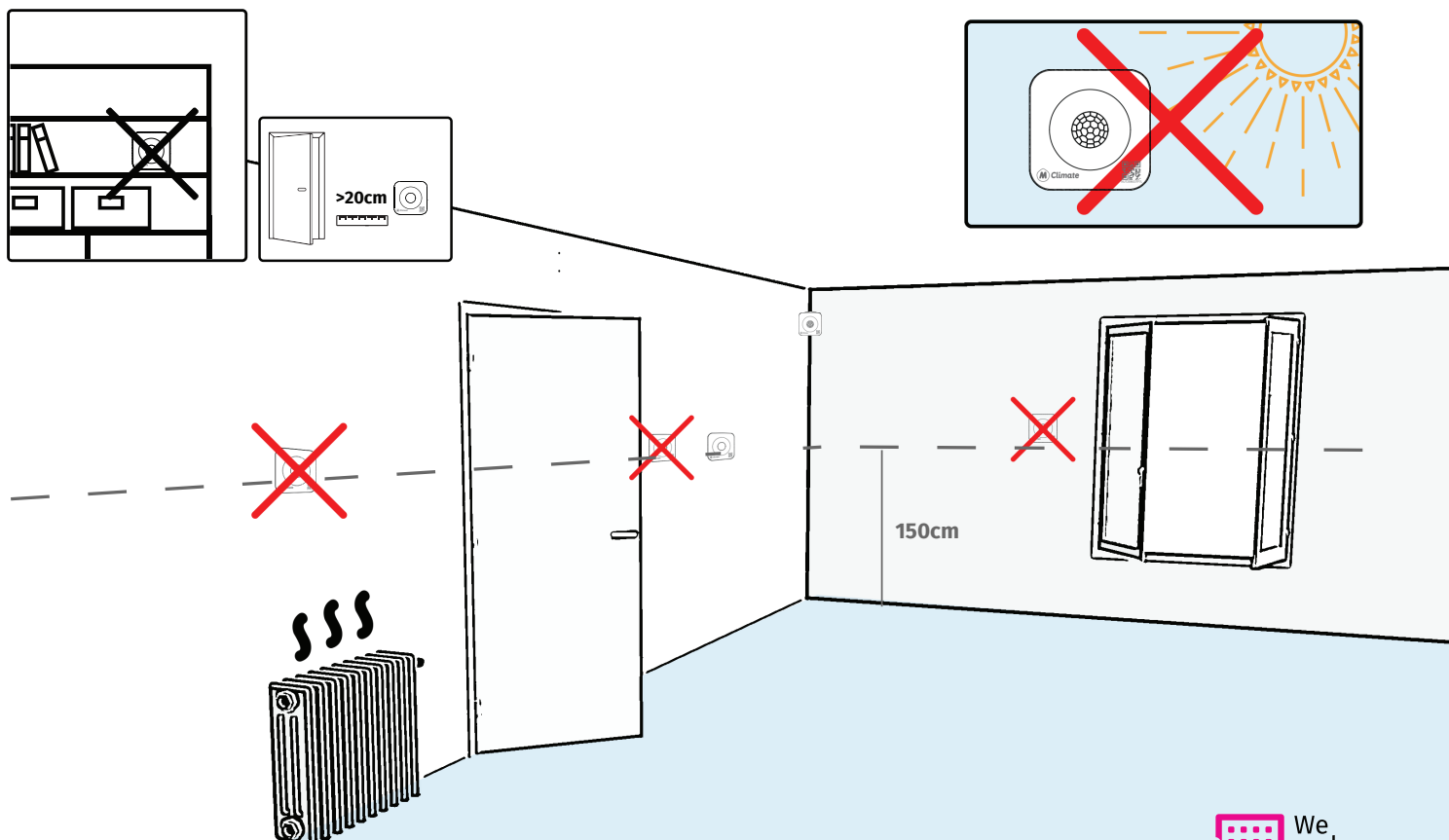

Optional accessories



45° mounting accessory for mini-series

ENCLOSURE	PP impact copolymer
DIMENSIONS	53mm x 53mm x 30mm
MOUNTING OPTIONS	Screws and dowels or double-sided tape

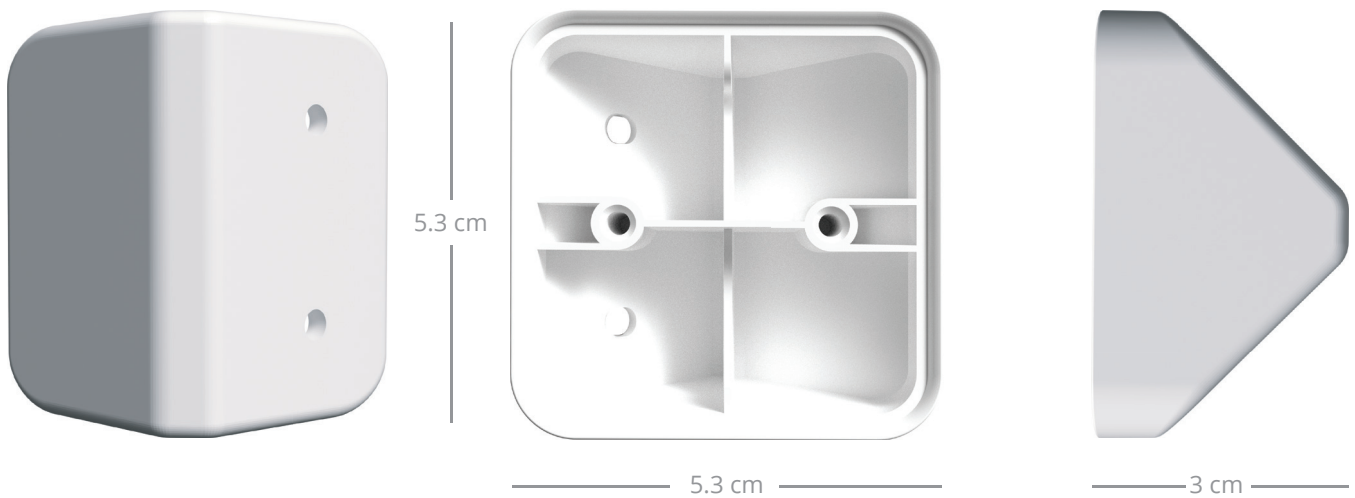



Adjustable Detection Angles

Five interchangeable limiter covers that reshape the PIR mini field of view to match the space — each tuned to a defined horizontal and vertical detection angle, with a mounting strategy to suit the space it serves.

Half moon

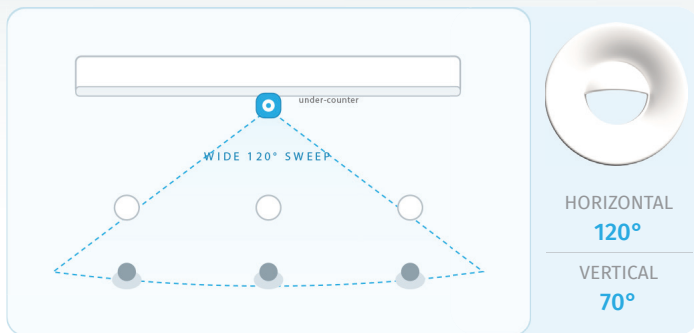

APPLICATION Wide areas viewed from a high or wall-edge mount where you want one half of the field and a clean cut-off on the other - corridors, lobbies, open-plan rooms and larger suites.

APERTURE GEOMETRY Half-disc (D-shaped) aperture - masks the lens along a straight edge.

BEHAVIOUR The sensor sees one half of its native field - full width on one side of the cut line, nothing on the other. With the flat edge horizontal it covers everything below (or above) the centre line; rotate the cover and the same half-field turns to one side.

Wedge

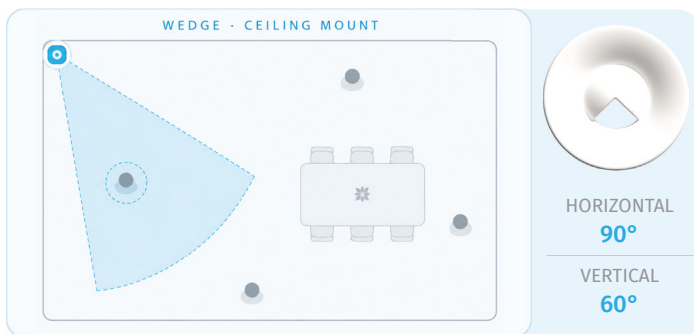

APPLICATION A single defined zone or corner of a larger room - meeting-room corners, alcoves and seating nooks in offices, hotels and care homes.

APERTURE GEOMETRY Small triangular (wedge) aperture.

BEHAVIOUR Confines detection to one corner or zone, so occupancy there is reported without the sensor triggering on the rest of the room.

Bowtie

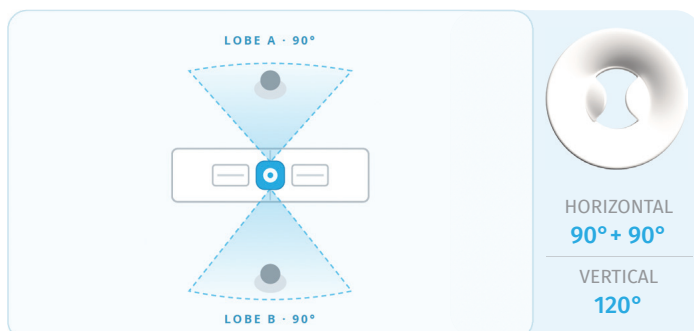

APPLICATION Paired positions served by one device - back-to-back or facing desks in offices, twin beds in hotel and care-home rooms.

APERTURE GEOMETRY Twin-lobe (split) aperture.

BEHAVIOUR Shapes the field into two opposing lobes so one sensor reaches two separate positions. Like every cover, it detects only within its field and ignores everything outside it.

Spot

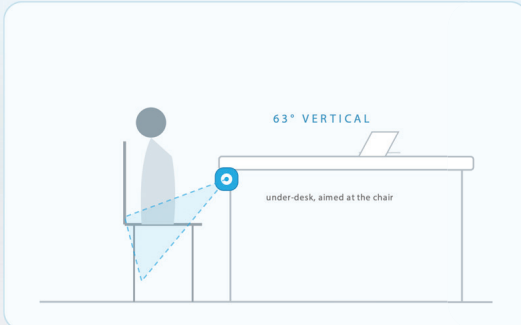

HORIZONTAL
93°
VERTICAL
63°

APPLICATION A single occupied position - individual desks and focus booths in offices, a chair or bedside in residential, hotel and care-home rooms.

APERTURE GEOMETRY Single off-axis oval aperture.

BEHAVIOUR One focused detection area — e.g. under-desk aimed at the chair — that catches the seated occupant while ignoring passing traffic.

Pinpoint

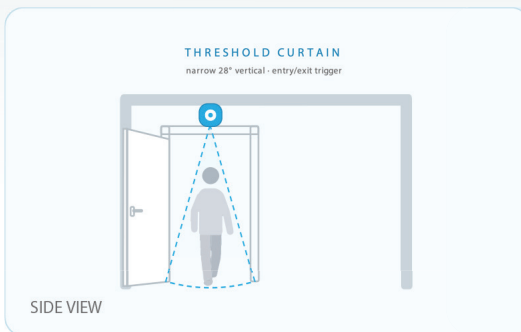

HORIZONTAL
28°
VERTICAL
28°

APPLICATION Doorways, entries, corridors, threshold counting

APERTURE GEOMETRY Small central circular aperture.

BEHAVIOUR A narrow cone over a single point - fires only as someone passes through it, giving clean entry/exit or crossing-count events.